



Universidad Tecnológica Nacional
Facultad Regional Haedo
Departamento de Ingeniería Electrónica

SISTEMAS DE COMUNICACIONES

DBL, BLU

Componentes de un SC

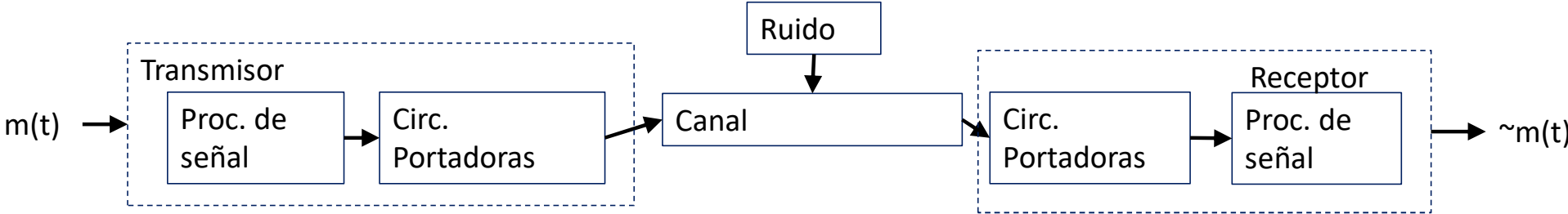

...

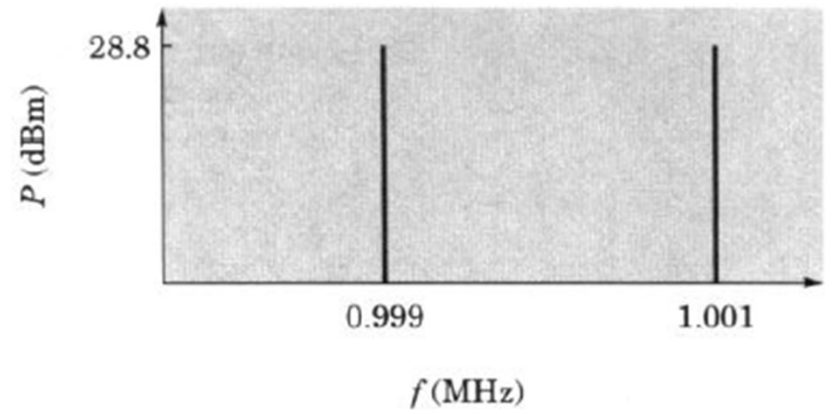
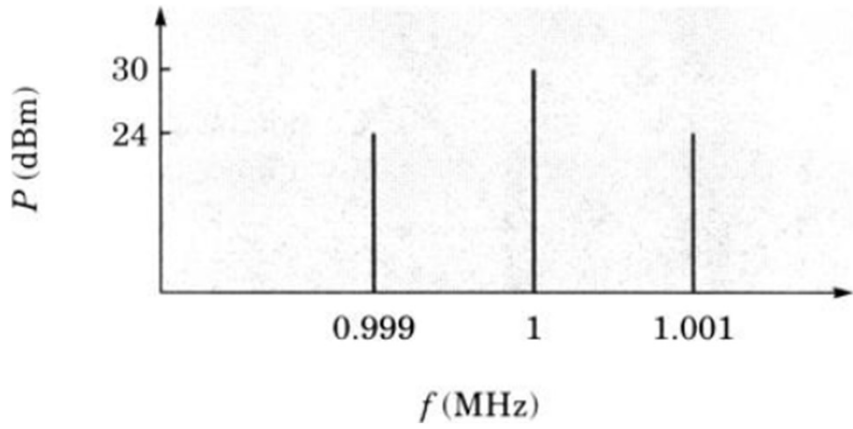
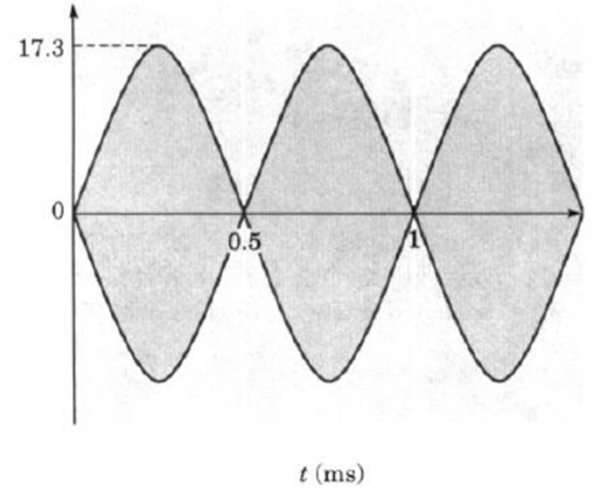
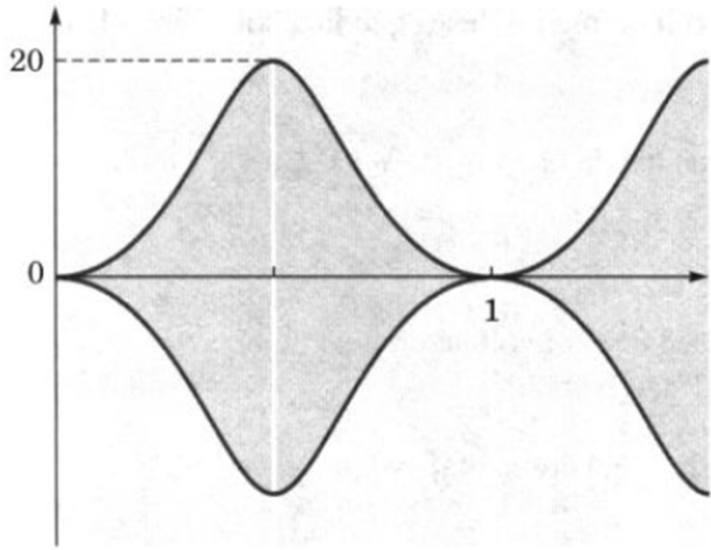

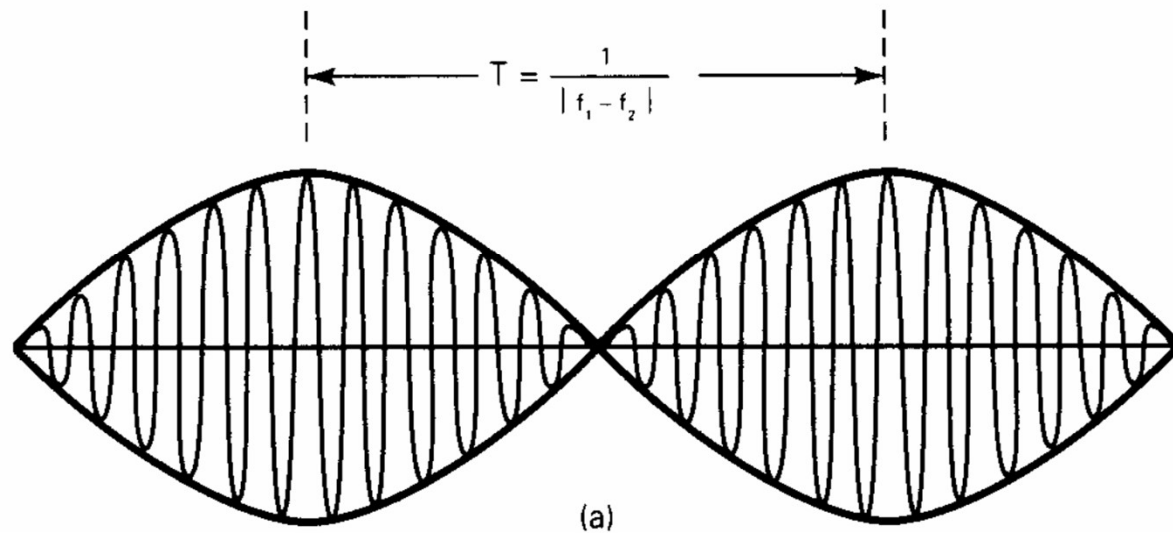

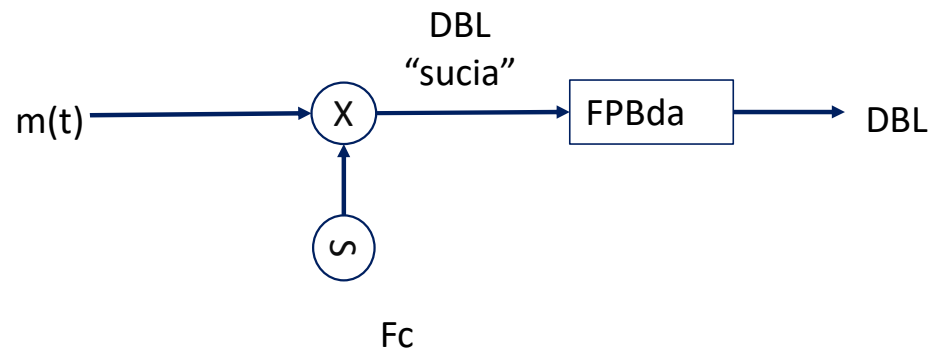

Modulación DBL

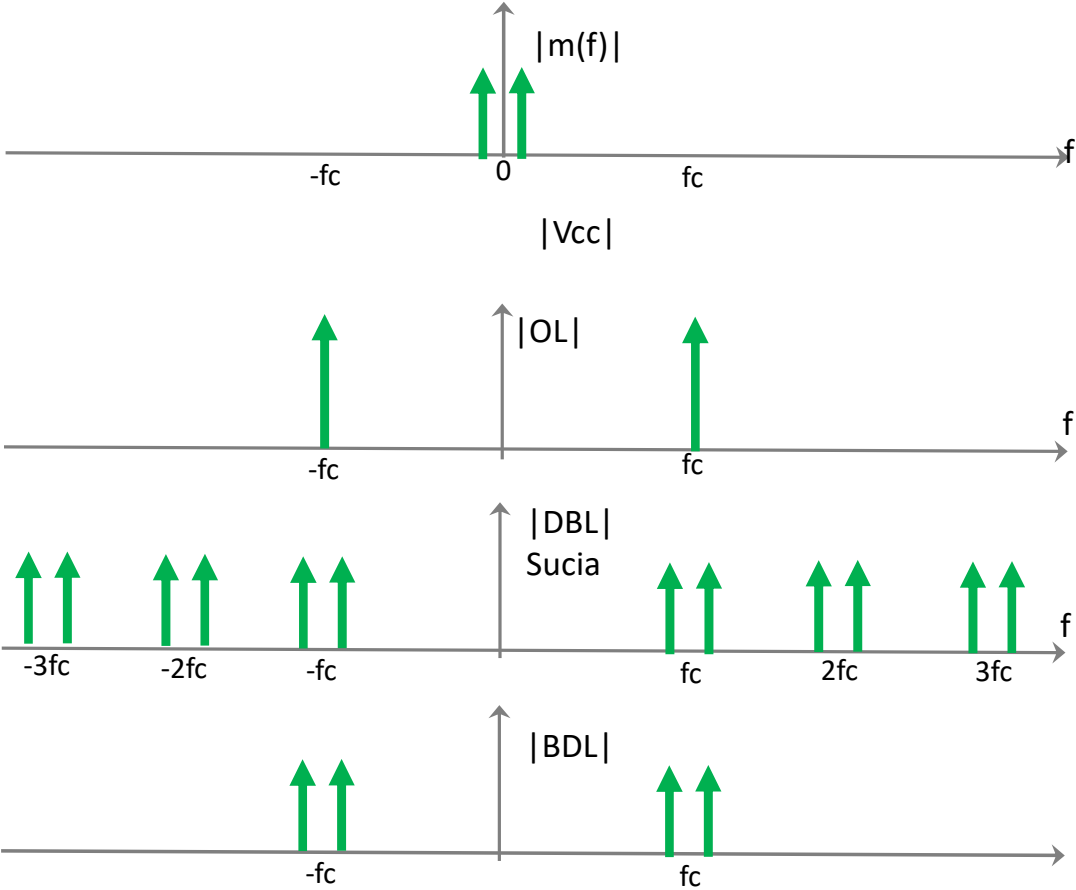

Modulación BLU

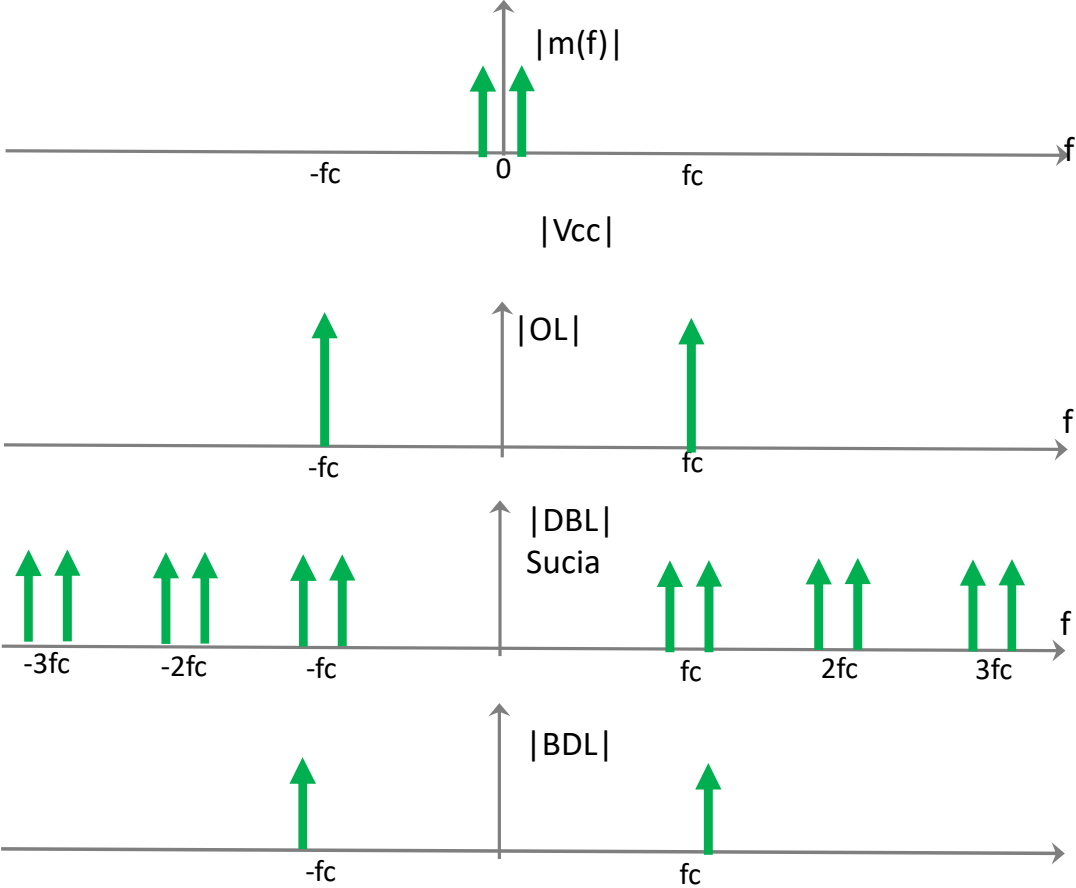

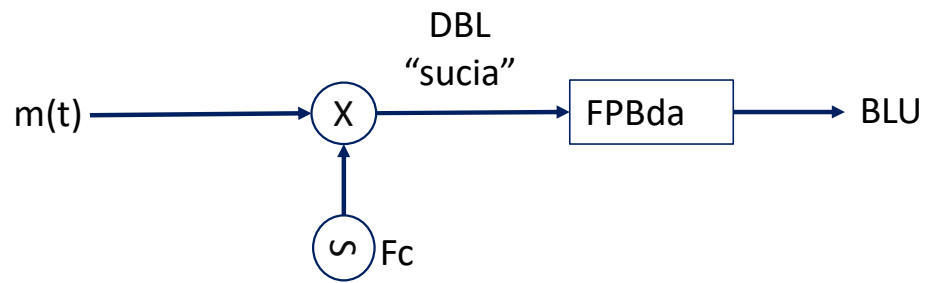

Modulación BLU: x Filtrado

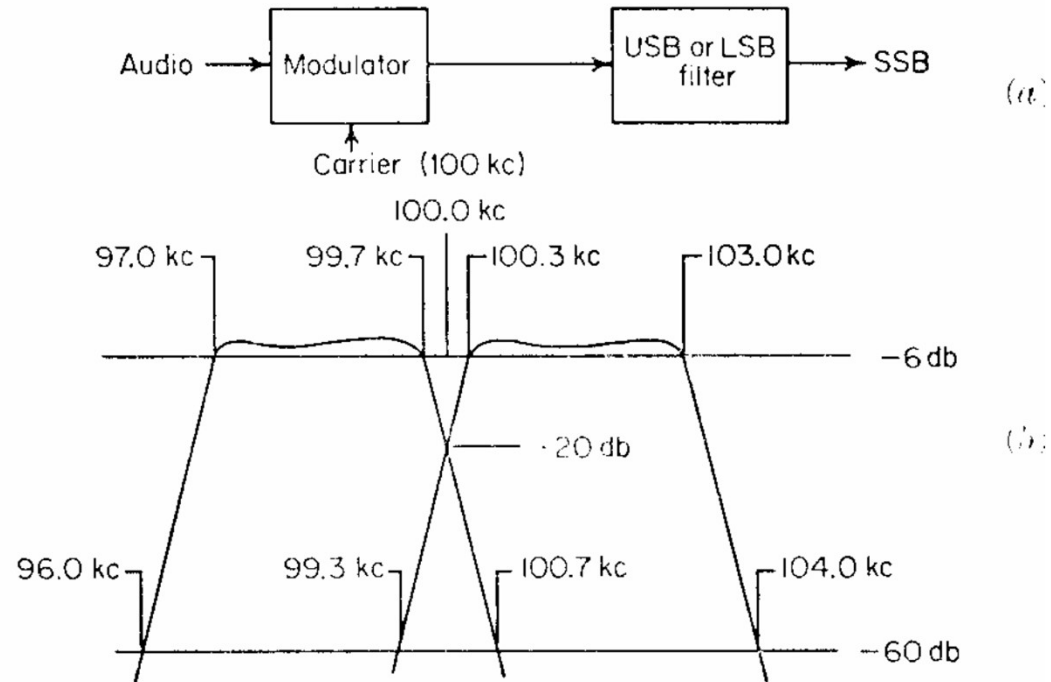

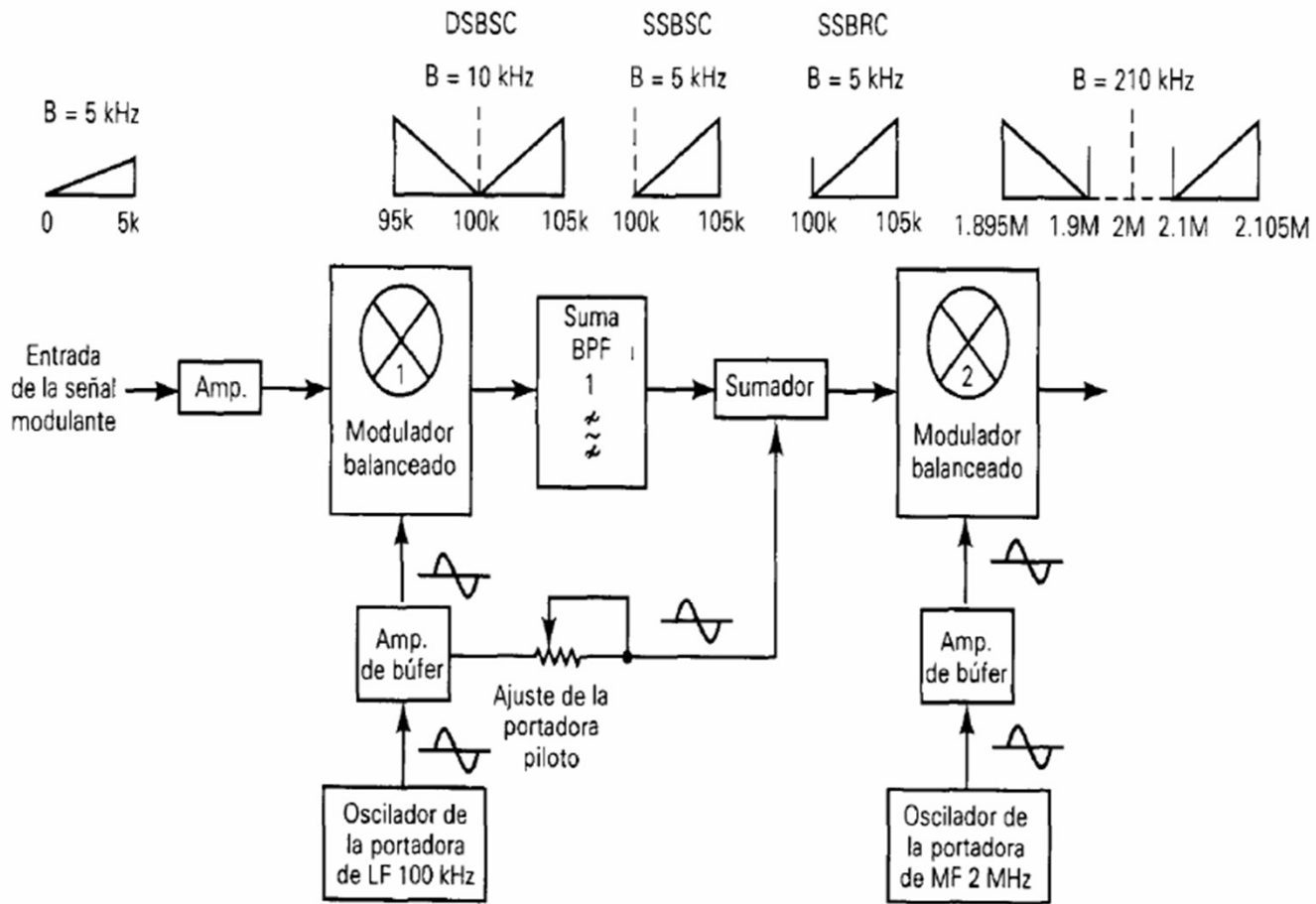

Moduladores: SLD

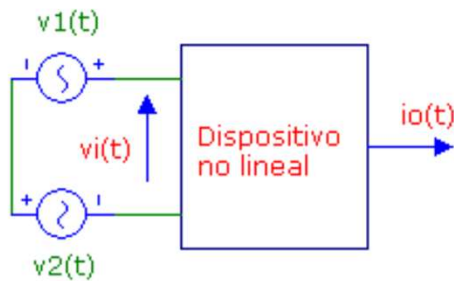

$$i_o(t) = I_o + a v_i(t) + b [v_i(t)]^2 + c [v_i(t)]^3 + \dots$$

$$i_o(t) = I_o + a v_i(t) + b [v_i(t)]^2$$

Si suponemos que la entrada es $v_i(t) = V_s \cos \omega_s t + V_o \cos \omega_o t$

Obtenemos: $i_o(t) = I_o + a(V_s \cos \omega_s t + V_o \cos \omega_o t) + b(V_s \cos \omega_s t + V_o \cos \omega_o t)^2$

$$i_o(t) = I_o + a(V_s \cos \omega_s t + V_o \cos \omega_o t) + b(V_s^2 \cos^2 \omega_s t + V_o^2 \cos^2 \omega_o t + 2V_s V_o \cos \omega_s t \cos \omega_o t)$$

$$i_o(t) = b V_s V_o [\cos(\omega_o - \omega_s)t + \cos(\omega_o + \omega_s)t]$$

Moduladores: H(t)

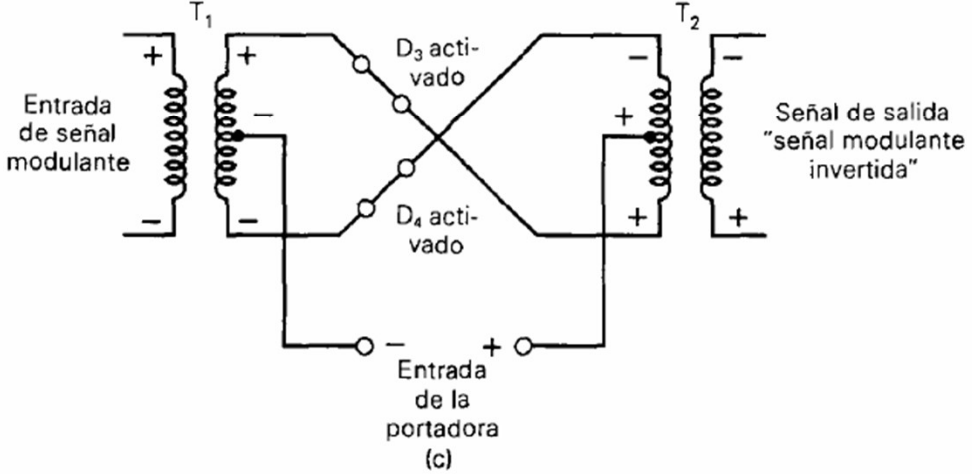
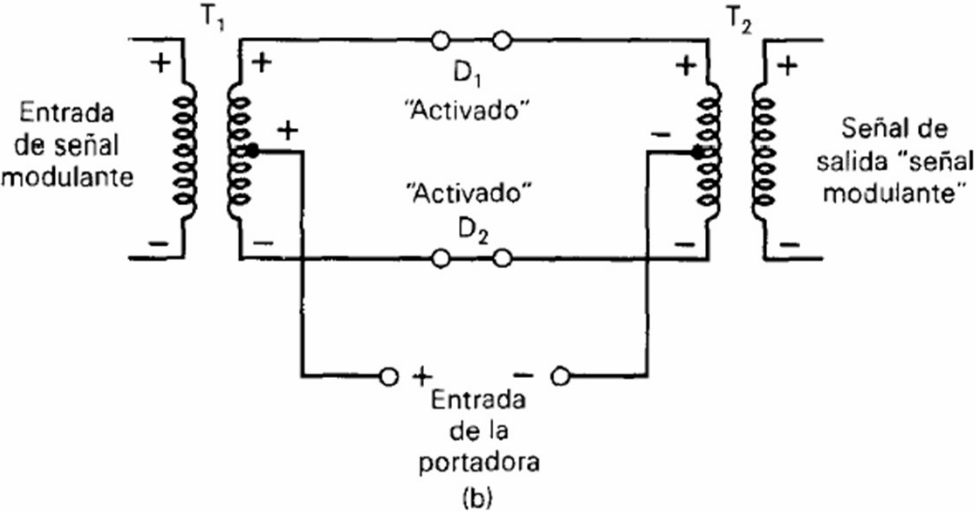
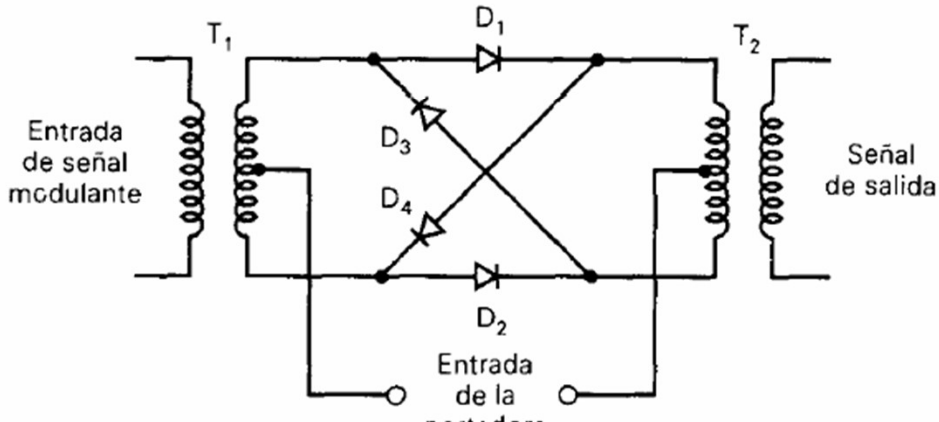

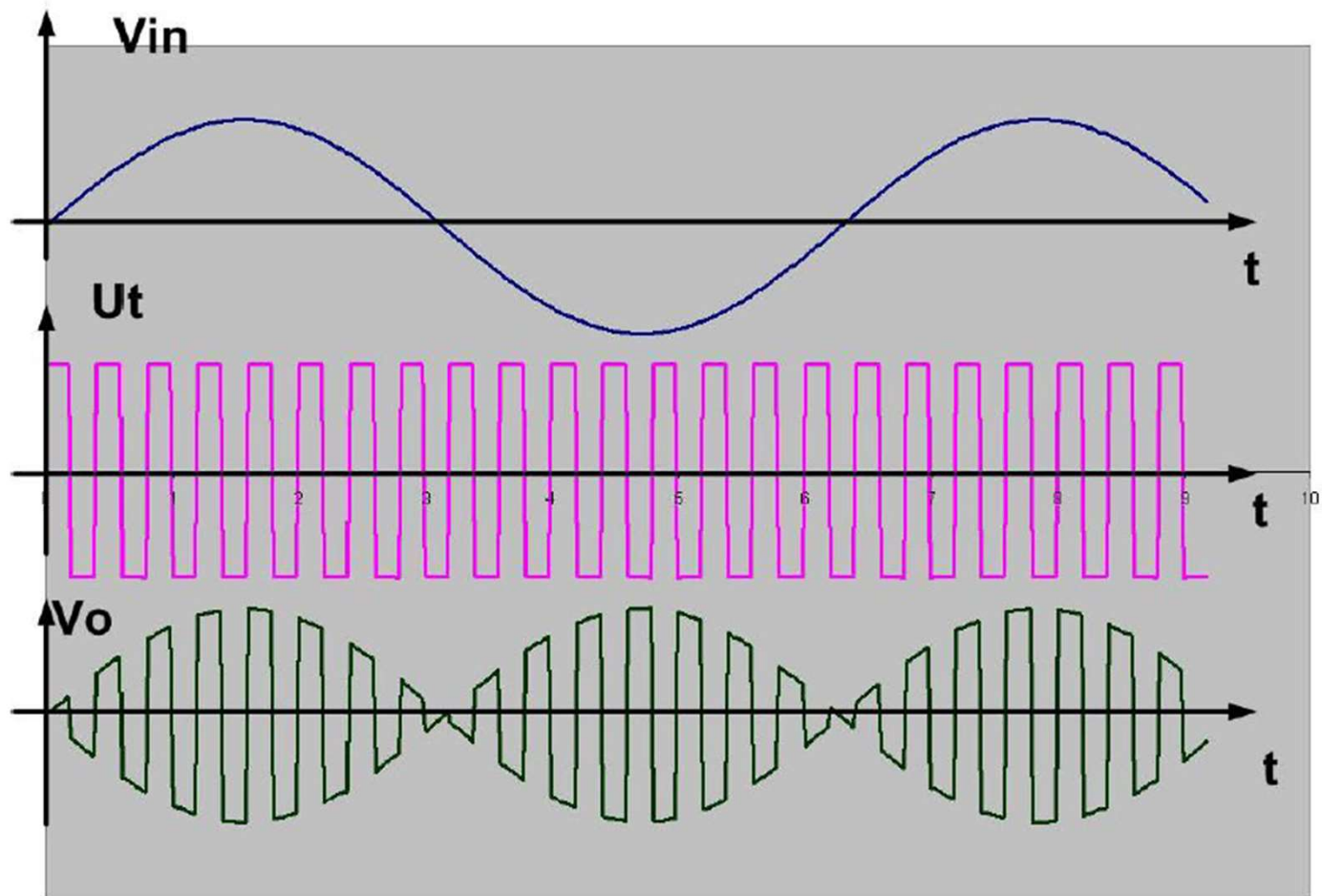

Modulación BLU: x Desfasaje

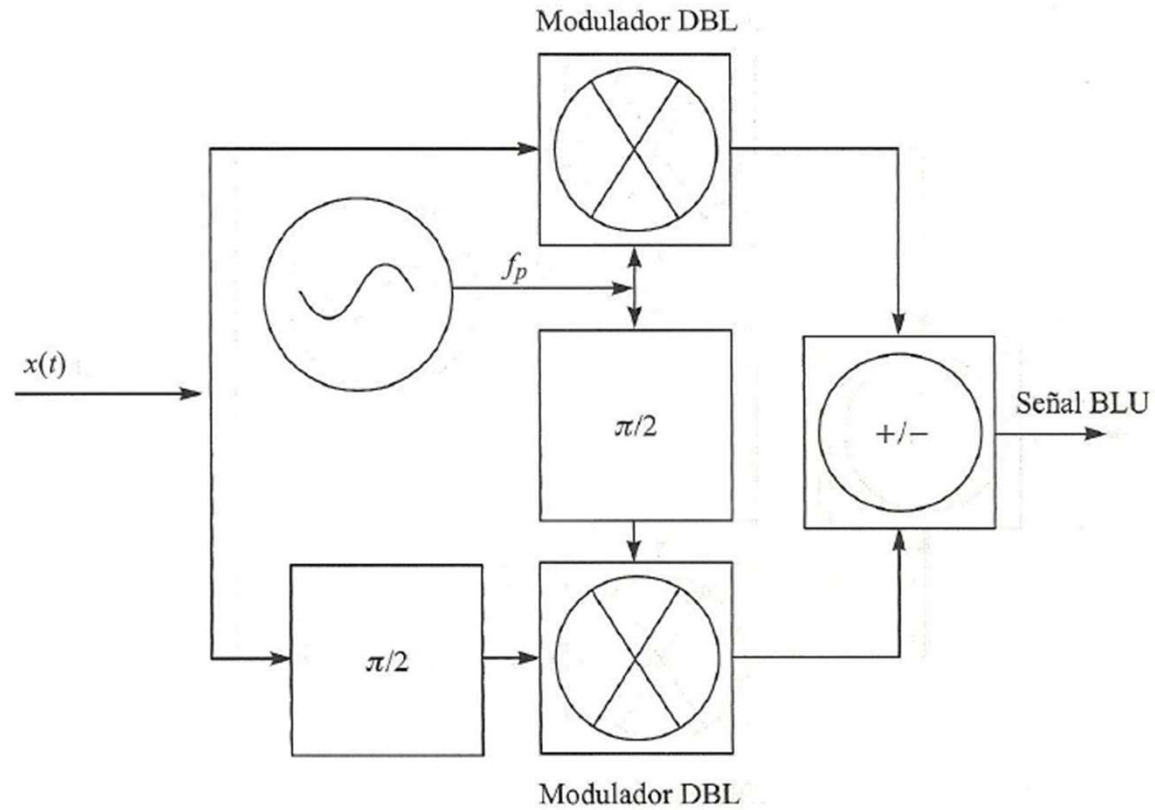

Demodulación DBL

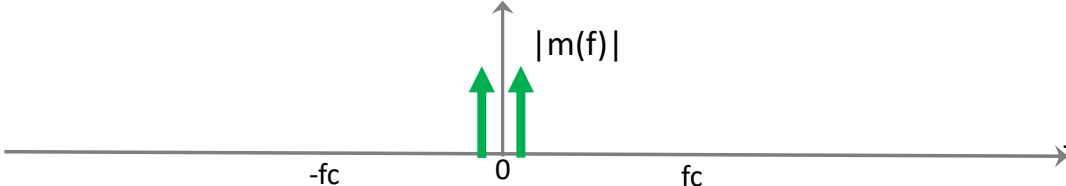
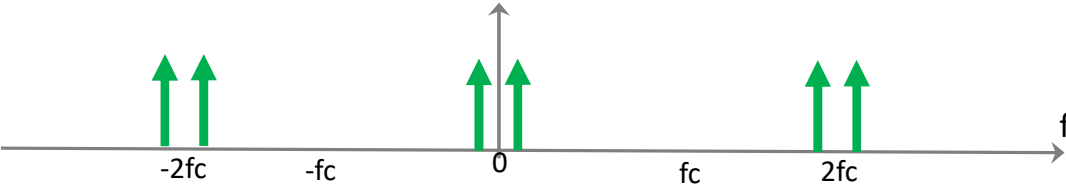
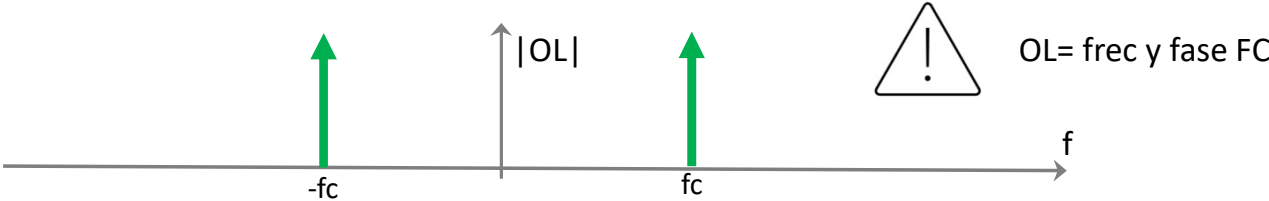
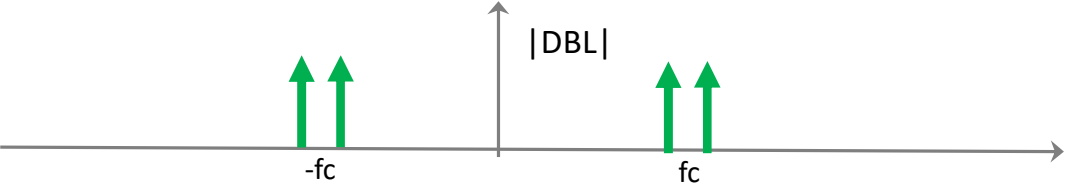

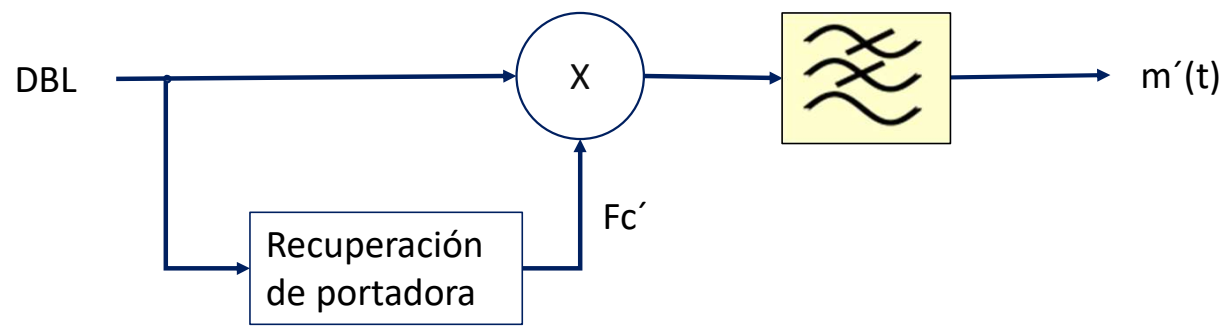

Demodulación BLU

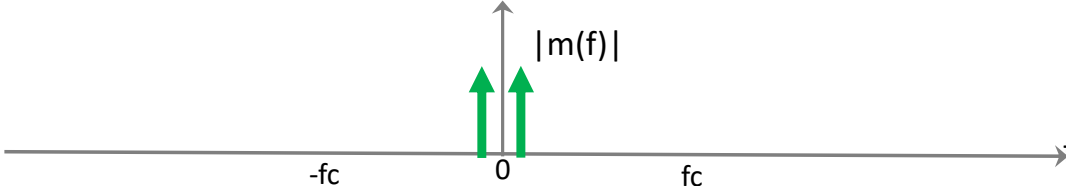
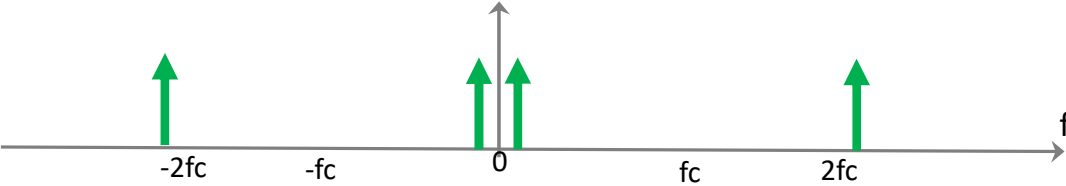
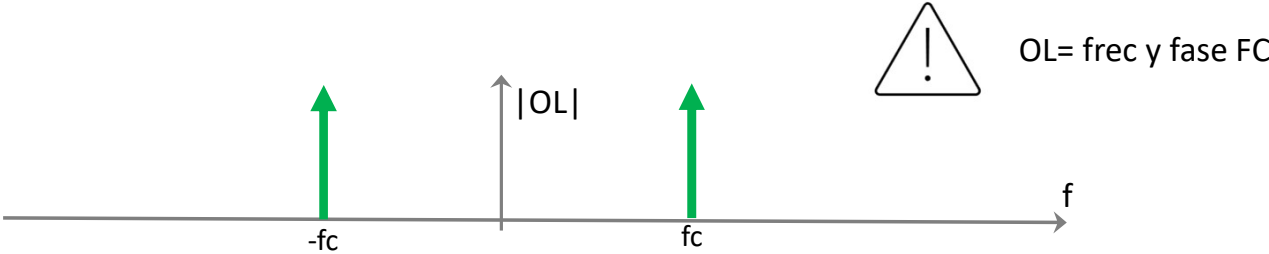
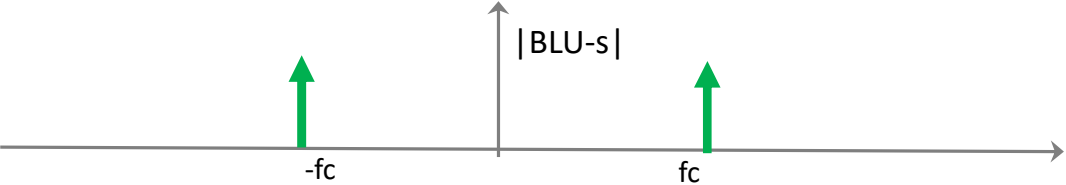

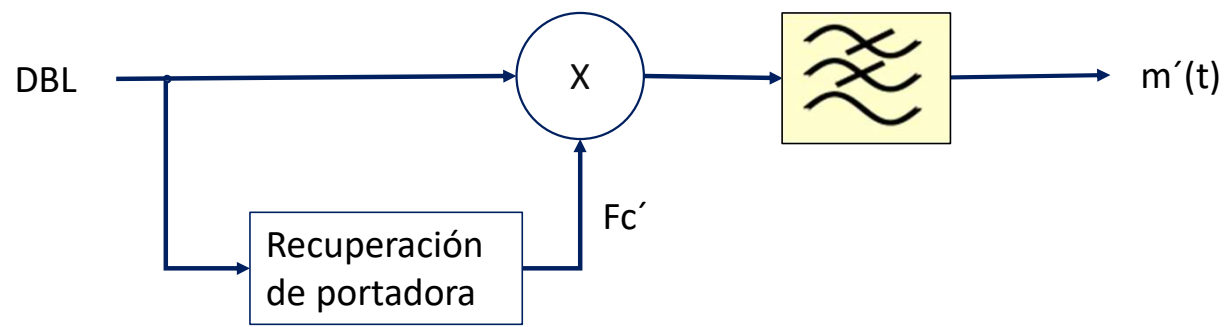

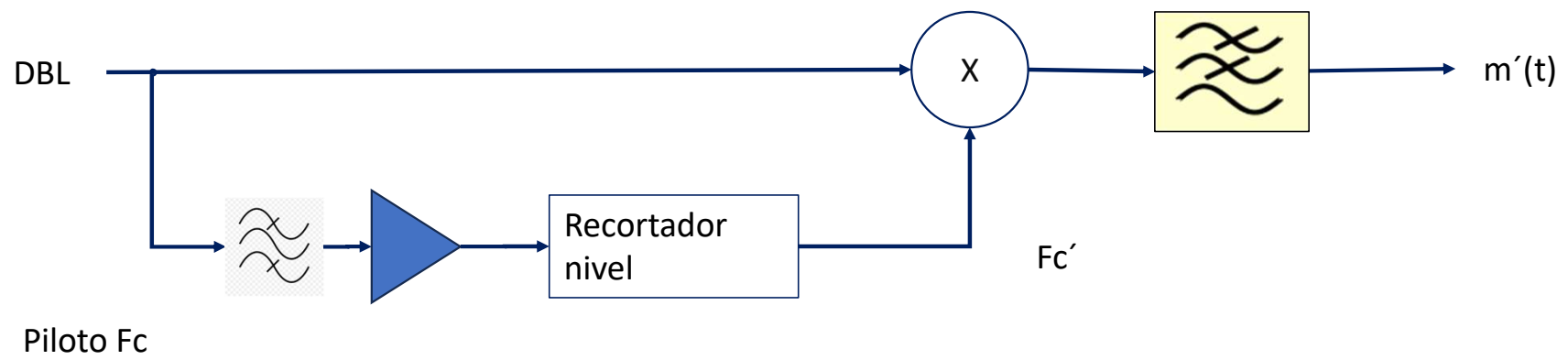

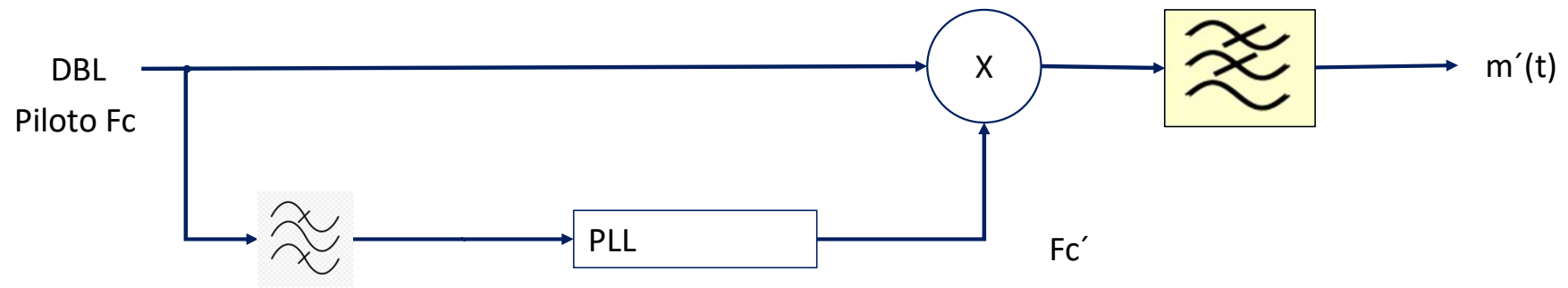

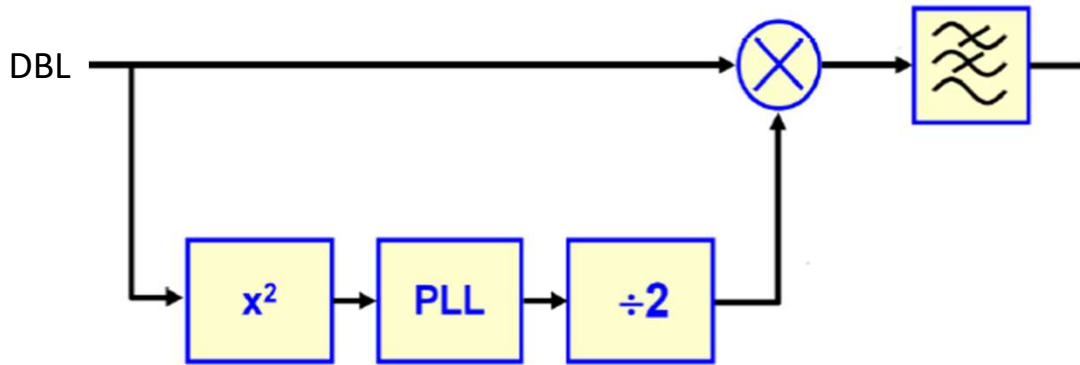

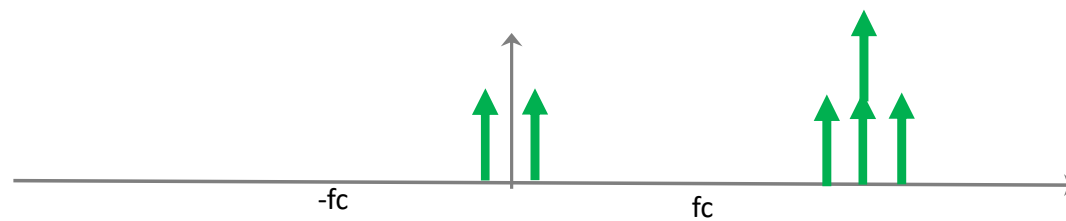
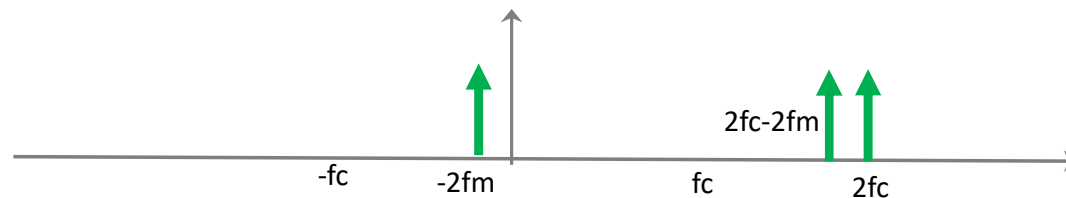
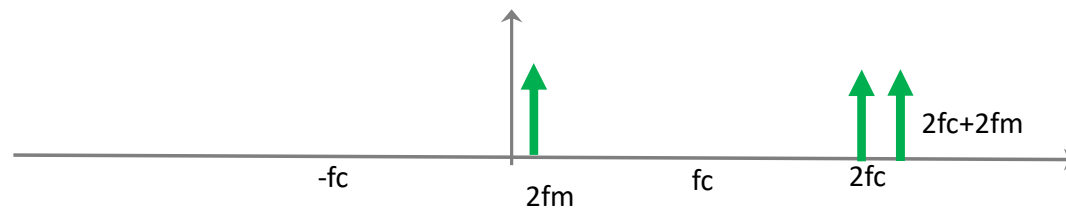
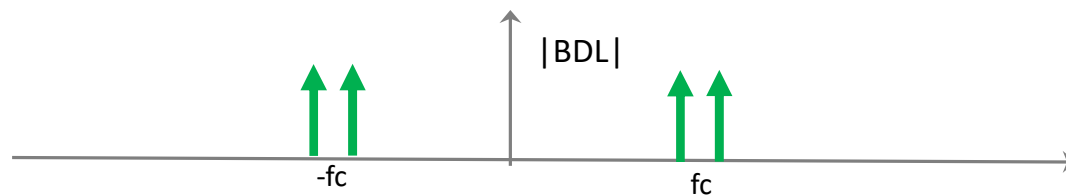

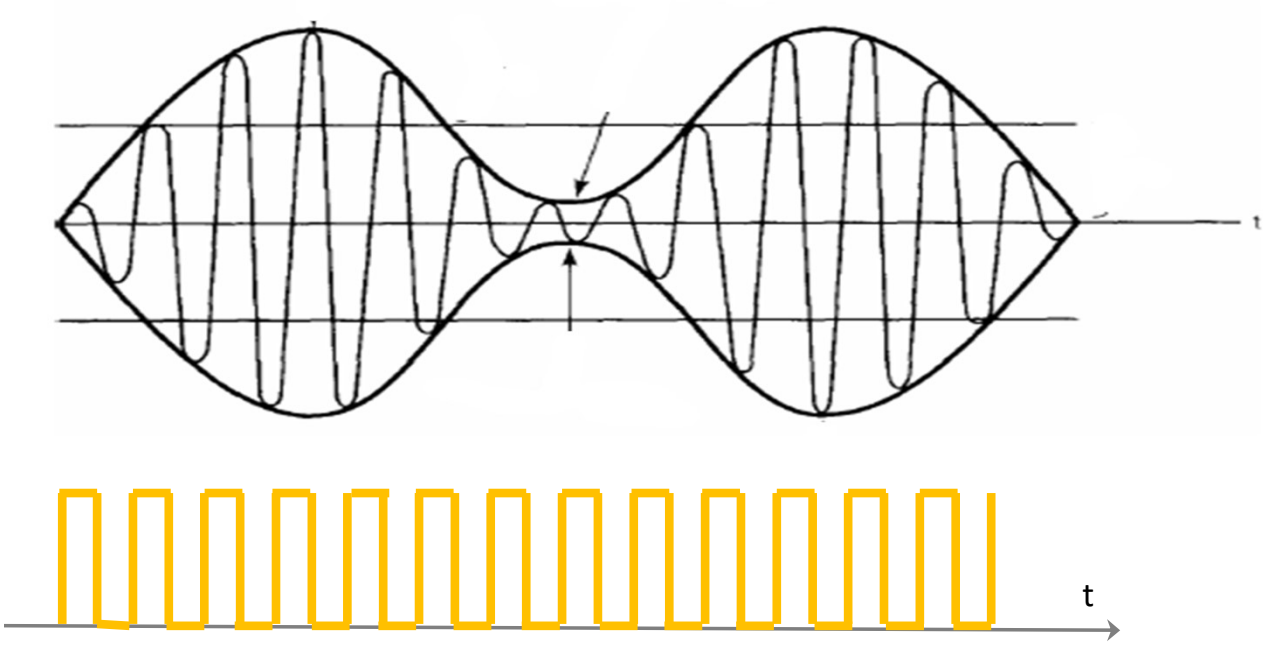

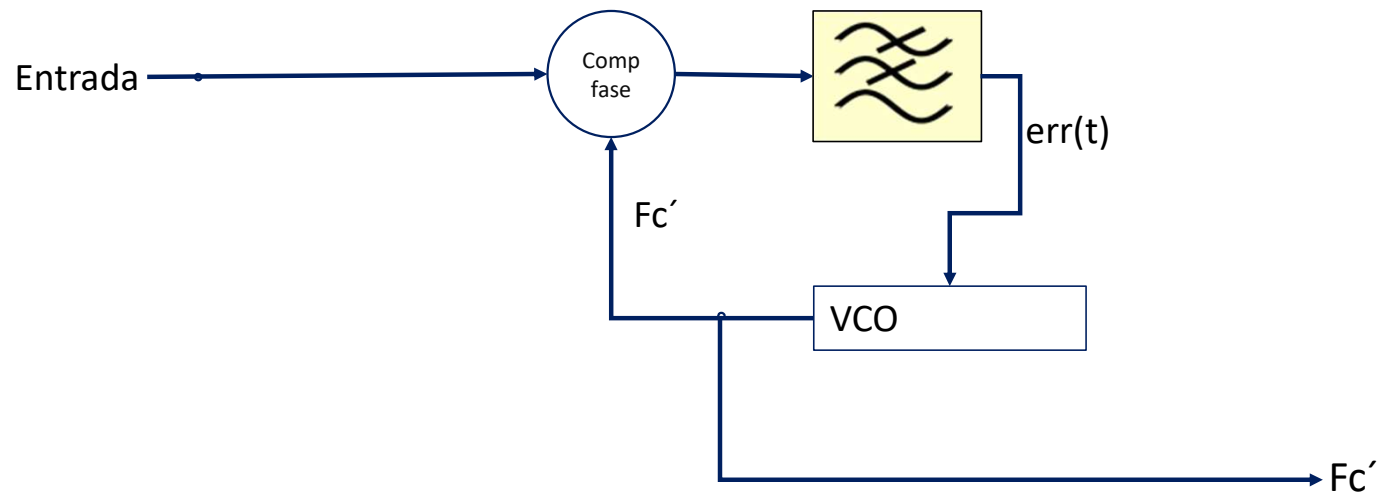



Universidad Tecnológica Nacional
Facultad Regional Haedo
Departamento de Ingeniería Electrónica